

iSolution™

Your *i*ntegrated Solution

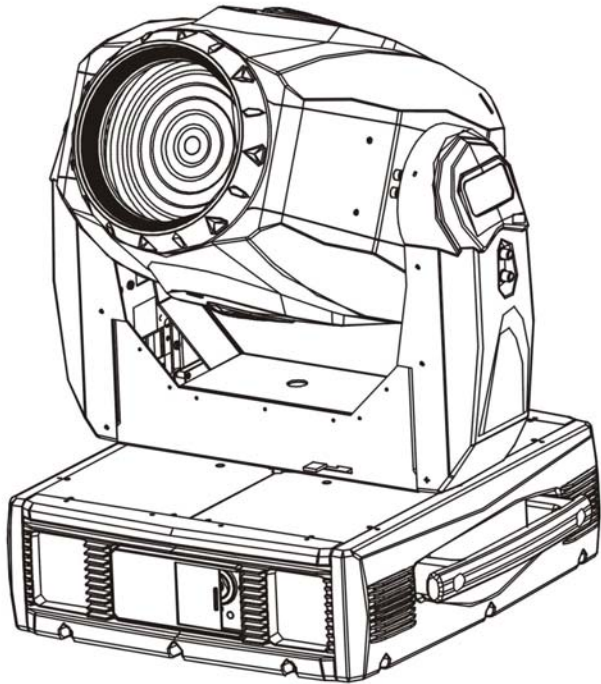

User manual



Version 1.0

TABLE OF CONTENTS

1. Safety Instruction
2. Technical Specification
 - 2.1 Description of the fixture
3. Lamp
4. How to Set the Unit
 - 4.1 Control Panel
 - 4.2 Main Function
5. How to Control the Unit
 - 5.1 DMX Controller
 - 5.2 DMX 512 Configuration
 - 5.3 DMX 512 Connection
6. Troubleshooting
7. Fixture Cleaning

1. Safety Instruction



WARNING

Please read carefully the instruction which include important information about the installation, usage and maintenance.

- Please keep this manual for future consultation.
- Unpack and check carefully there is no transportation damage before using the unit.
- Before operating, be ensure that the voltage and frequency of power supply match the power requirements of the unit.
- The unit is designed for MSI 1200W/S, HMI 1200/S or HMQ 1200/S lamp (SFc10-4). Do not use any other type of lamps.
- It's important to ground the yellow/green conductor to earth to avoiding electric shock.
- The unit is for indoors use in dry location.
- The unit must be installed in a location with adequate ventilation, at least 50 cm from adjacent surfaces. Be sure that no ventilation slots are blocked.
- Disconnect main power before fuse/lamp replacement or servicing.
- Replace fuse/lamp only with the same type.
- Make sure there are no flammable materials close to the unit while operating, as it is fire hazard.
- Use safety chain when fixing this unit. Don't handle the unit by taking its head only, but always by it's base.
- Maximum ambient temperature is TA : 40°C. Don't operate it where the temperature is higher than 40°C.
- Unit surface temperature may reach up to 85°C. Don't touch the housing bare-hand during its operation, and waiting for 15 minutes to cool down before replacing bulb or serving, as the unit could be very hot.
- Stop using the unit immediately when malfunction. Never try to repair the unit by yourself. Repairs carried out by unskilled people can lead to damage or malfunction. Please contact the nearest authorized technical assistance center. Always use the same type spare parts.
- Don't connect the device to any dimmer pack.
- Do not touch any wires during operation, as it might be a hazard of electric shock.

Warning

- To prevent or reduce the risk of electrical shock or fire, do not expose the unit to rain or moisture.
- Never touch bulb with bare fingers, as it is very hot after using.
- Hot lamp explosion hazard. Do not open the unit within five minutes after switching off.
- Do not start on the unit without bulb enclosure or when housing is damaged.
- The housing, lenses or the ultraviolet filter must be replaced if they are visibly damaged.
- The light beam will damage your retina, please do not look the light directly.

Caution

- There are no user serviceable parts inside the unit. Do not open the housing or attempt any repairs by yourself. If the unit need any require service, please contact your nearest dealer.

Installation

The unit should be mounted via its mounting system on the bottom of the base. Use clamps to fix the unit to truss. Always ensure that the unit is firmly fixed to avoid vibration and slipping while operating. Always ensure that the structure to which you are attaching the unit is secure and is able to support a weight of 50 kg for each unit.

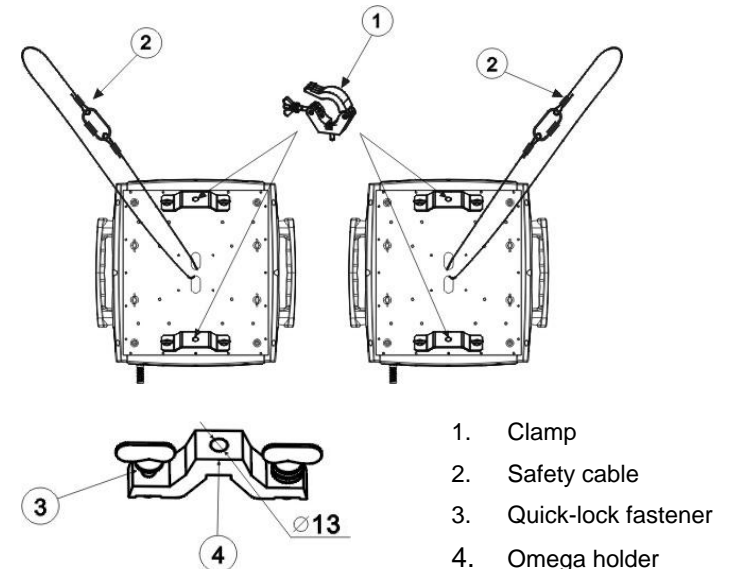

2. Technical Specification

Power supply

- AC 208V/230V/240V/250V ~50Hz

Lamp

- MSI 1200W/S / HMI 1200/S / HMQ 1200/S SFC10-4

Optical system

- High efficiency optical system
- High quality optical lens and dichroic colors
- Beam angle: 11°~22°

Shutter/Dimmer

- Blackout, 0~100% smooth dimming and strobe speed variable (1~10 flashes/second)

Color wheel

- Independent color wheel with 6 dichroic colors plus white
- Color wheel rotates with variable speed and display rainbow effect.

CMY Mixing system

- CMY color and 3200k color lens mixing system

Effect Wheel

- Frost filter and diagonal lens

Movement

- Pan: 540° in 2.8 second.
- Tilt: 270° in 1.6 second.
- Pan/Tilt resolution: 8/16-bit.
- Automatic Pan/Tilt correction.
- Automatic Pan/Tilt home positioning.
- Pan/Tilt position lock for transporting protection.

Zoom

- Automatic zoom by DMX controls.

Luminous intensity:

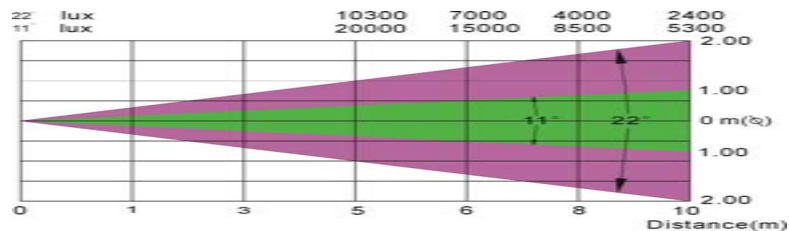

4A

DMX Channels : (control by any universal DMX controller)

22 Channels Mode	16 Channels Mode
Channel 1 = pan	Channel 1 = pan
Channel 2 =Tilt	Channel 2 =Tilt
Channel 3 =pan/Tilt speed	Channel 3 =pan/Tilt speed
Channel 4 =Dimmer	Channel 4 =Dimmer
Channel 5 =Shutter	Channel 5 =Shutter
Channel 6 =Color wheel	Channel 6 =Color wheel
Channel 7 =Cyan	Channel 7 =Cyan
Channel 8 =Magenta	Channel 8 =Magenta
Channel 9 =Yellow	Channel 9 =Yellow
Channel 10 =3200K filter	Channel 10 =3200K filter
Channel 11 =Color-mix preset	Channel 11 =Color-mix preset
Channel 12 =Color macro	Channel 12 =Color macro
Channel 13 =Color macro speed	Channel 13 =Color macro speed
Channel 14 =Zoom	Channel 14 =Zoom
Channel 15 =Effect	Channel 15 =Effect
Channel 16 =Lamp on/off/Reset	Channel 16 =Lamp on/off/Reset
Channel 17 =pan movement fine	
Channel 18 =Tilt movement fine	
Channel 19 =pan/Tilt macro	
Channel 20 =pan/Tilt macro speed	
Channel 21 =Dimmer fine	
Channel 22 =Dimmer fine speed	

Weight: 44.2 kg

Dimension: 517x 704 x 480 mm

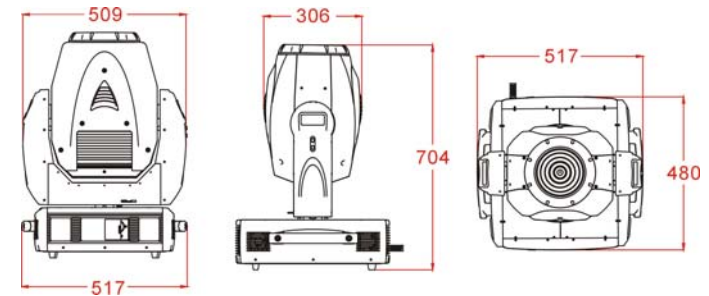

5A

2.1. Description of the fixture

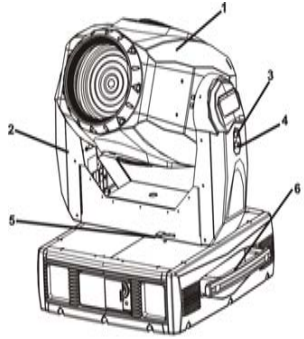

1. Moving head
2. Yoke
3. Tilt lock button (red)
4. Tilt unlock button (green)
5. Pan lock/unlock lever
6. Handle

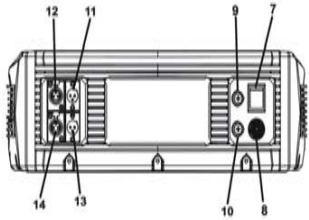

7. Power switch
8. Power cord
9. Lamp fuse
10. Power cord EL Fuse
11. DMX In 3-Pin XLR
12. DMX Out 3-Pin XLR
13. DMX In 5-Pin XLR
14. DMX Out 5-Pin XLR

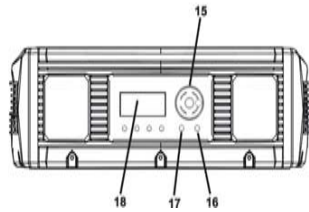

15. Jog wheel
16. Enter button
17. Esc button
18. LCD display

2. Lamp



WARNING

In case of replacement of the lamp or maintenance, do not open the fixture when power off it within 15 minutes.

Because of its high internal pressure, there might be a risk that the Discharge lamp would explode during operation. The lamp emits intense UV radiation which is harmful to the eyes and skin. The high luminance of the arc can cause severe damage to the retina if looks directly at the lamp.

MSI 1200W/S, HMI 1200/S, HMQ 1200/S K SFc 10-4

1. Always switch off the main supply and never handle the lamp when it is hot.
2. Do not touch the bulb with bare hands. If this happens, clean the lamp with denatured alcohol and wipe it with a lint free cloth before installation.
3. The lamp generates UV radiations Never operate the lamp without appropriate shielding.
4. When power on the unit, the lamp is during high pressure and there is a slight risk of arc tube rupture. The risk increases with age, temperature and improper handling of the lamp. Do not use the lamp any longer than its lifespan.
5. Make sure the lamp is located in the center of the reflector for the best spot.

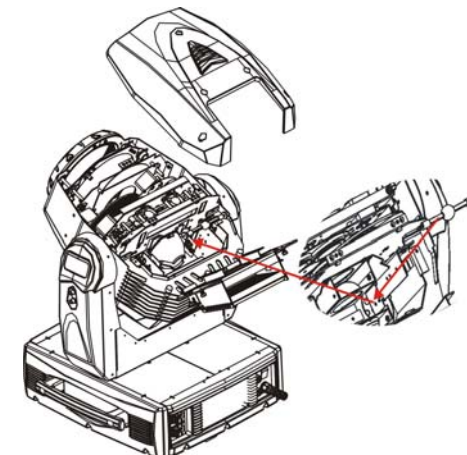

6. If changing the lamp, remove old lamp from lamp socket. Hold the new lamp only by its ceramic base. Never touch the glass bulb. Insert the new lamp in the lamp socket.
7. Please turn the head in horizontal position. Hinge must be on the upper side of the head. Turn screws left and remove plastic cover. Loosen head screw and open the lamp cover
8. With the nipple of the lamp facing the back insert one end of the lamp into the socket. Pull up the spring of the other side of the socket and snap the other end of the lamp into place. Make sure it fits correctly into the socket. Please refer to the diagram to know how to put the lamp in correct position.

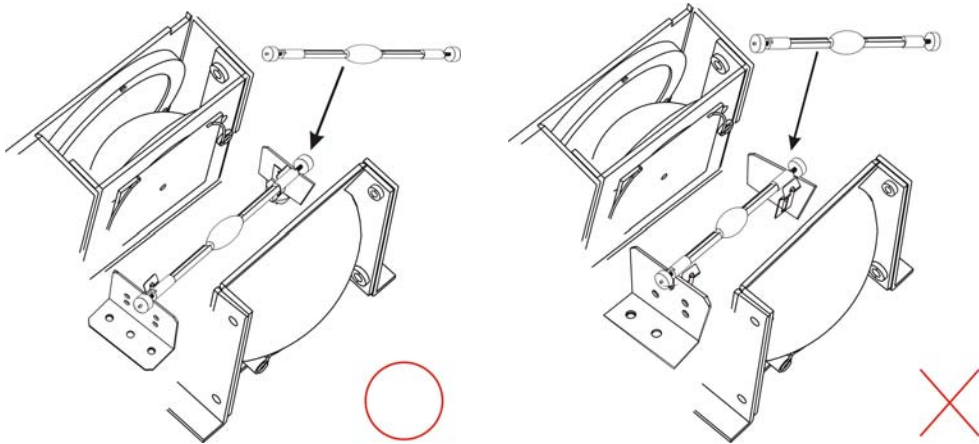

4. How To Set The Unit

4.1 Control Panel

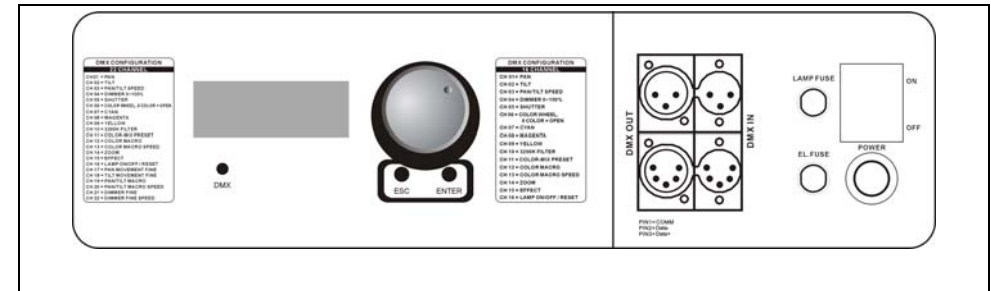

LCD monitor	To show the various menus .
DMX LED	DMX input present
ESC Button	To go back to the previous functions
ENTER Button	To confirm the selected functions
Jog wheel	To select the given functions
On/Off switch	Turns On/Off the power
Fuse	To replace the fuse
Power cord	To connect the power plug
3-pin XLR DMX input/output	For DMX 512 operation, use 3-pin XLR plug cable to link the unit together
5-pin XLR DMX input/output	For DMX 512 operation, use 5-pin XLR plug cable to link the unit together

4.2 Main Function

To select any of the pre-set functions, press the **ENTER** button and turn jog wheel until the required one is shown on the monitor. Select the function by **ENTER** button. Use the jog wheel to change the mode. Once the required mode has been selected, press the **ENTER** button to setup or it will automatically return to the main functions without any change after idling 10 seconds. To go back to the previous functions without any change press the **ESC** button. The main functions are shown below:

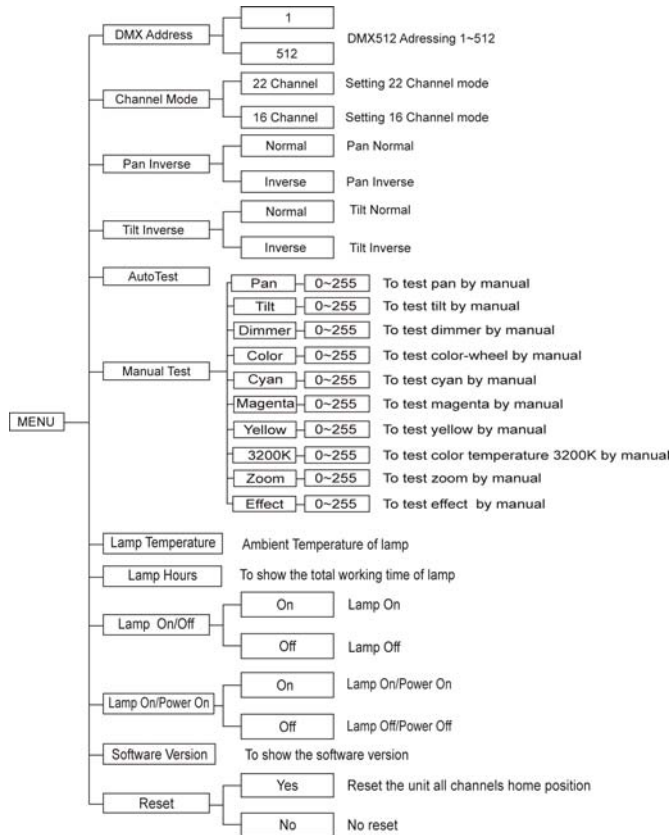

DMX 512 Address Setting

Press the **ENTER** button and turn jog wheel until the **DMX Address** is shown on the monitor. Pressing **ENTER** button and the display will blink. Use jog wheel to change the DMX 512 address. Once the address has been selected, press the **ENTER** button to setup or automatically return to the main functions without any change after 10 seconds. To go back to the previous functions without any change press the **ESC** button.

Channel Mode

Press the **ENTER** button and turn jog wheel until the Channel Mode is shown on the monitor. Pressing **ENTER** button and the display will blink. Use jog wheel to select the (16 Channel) or (22 Channel) mode. Once the mode has been selected, press the **ENTER** button to setup or automatically return to the main functions without any change after 10 seconds. To go back to the previous functions without any change press the **ESC** button.

Pan Inversion

Press the **ENTER** button and turn jog wheel until the **Pan Inversion** is shown on the monitor. Pressing **ENTER** button and the display will blink. Use jog wheel to select the (Normal) or (Inversion) mode. Once the mode has been selected, press the **ENTER** button to setup or automatically return to the main functions without any change after 10 seconds. To go back to the previous functions without any change press the **ESC** button.

Tilt Inversion

Press the **ENTER** button and turn jog wheel until the **Tilt Inversion** is shown on the monitor. Pressing **ENTER** button and the display will blink. Use jog wheel to select the (Normal) or (Inversion) mode. Once the mode has been selected, press the **ENTER** button to setup or automatically return to the main functions without any change after 10 seconds. To go back to the previous functions without any change press the **ESC** button.

Auto Test

Press the **ENTER** button and turn jog wheel until the **Auto Test** is shown on the monitor. Pressing **ENTER** button and the display will blink. select option and the unit will run self-test by built-in program. To go back to the main functions press the **ESC** button twice.

Manual Test

Press the **ENTER** button and turn jog wheel until the **Manual Test** is shown on the monitor. Pressing **ENTER** button and the display will blink. Use jog wheel to select the (Pan) or (Tilt) or (Dimmer) ormode. Once the mode has been selected, press the **ENTER** button and use jog wheel to select the 0~255 value. Once the value has been selected, press the **ENTER** button to setup or automatically return to the main functions without any change after 10 seconds. To go back to the previous functions without any change press the **ESC** button.

Lamp Temperature

Press the **ENTER** button and turn jog wheel until the **Lamp Temperature** is shown on the monitor. Pressing **ENTER** button and the ambient temperature of lamp will show on the monitor. To go back to the main functions press the **ESC** button twice.

Lamp Hours

Press the **ENTER** button and turn jog wheel until the **Lamp Hours** is shown on the monitor. Pressing **ENTER** button and the monitor will show the number of working hours of the unit. To go back to the main functions press the **ESC** button twice.

Lamp On/Off

Press the **ENTER** button and turn jog wheel until the **Lamp On/Off** is shown on the monitor. Pressing **ENTER** button and the display will blink. Use jog wheel to select the (Lamp on) or (Lamp off) mode. Once the mode has been selected, press the **ENTER** button to setup or automatically return to the main functions without any change after 10 seconds. To go back to the previous functions without any change press the **ESC** button.

Lamp On/Power On

Press the **ENTER** button and turn jog wheel until the **Lamp On/Power On** is shown on the monitor. Pressing **ENTER** button and the display will blink. Use jog wheel to select the (on) or (off) mode. Once the mode has been selected, press the **ENTER** button to setup or automatically return to the main functions without any change after 10 seconds. To go back to the previous functions without any change press the **ESC** button.

Software Version

Press the **ENTER** button and turn jog wheel until the **Software Version** is shown on the monitor. Pressing **ENTER** button and the display will blink. Use jog wheel to select the (A) or (B) or (C) or (D) mode. Once the mode has been selected, press the **ENTER** button to setup or automatically return to the main functions without any change after 10 seconds. To go back to the previous functions without any change press the **ESC** button.

Reset

Press the **ENTER** button and turn jog wheel until the **Reset** is shown on the monitor. Pressing **ENTER** button and the display will blink. Use jog wheel to select the (Yes) or (No)

mode. select (Yes) option and all channels of the unit will return to their standard position. To go back to the main functions press the **ESC** button twice.

4.3. Home Position Adjustment

Press the **ENTER** button for at least 5 seconds into offset mode, turn jog wheel until the function is shown on the monitor pressing **ENTER** button again into the next function. Once the function has been selected, use jog wheel to adjust this settings only for offset mode to adjust home position. To go back to the previous functions without any change press **ESC** button. The functions are shown below:

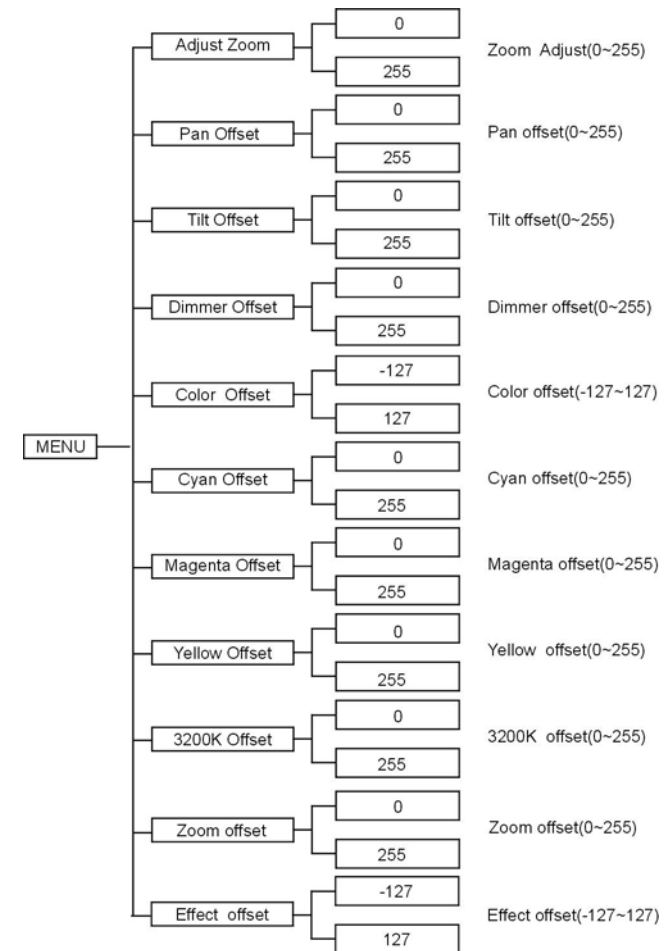

5. How To Control The Unit

The unit can be operating by any universal DMX controllers.

No need to turn the unit off when you change the DMX address, as new DMX address setting will be effected at once. Every time you turn the unit on, it will show “e-2510 resetting...” on the monitor and move all the motors to their ‘home’ position and you may hear some noises for about 20 seconds. After that the unit will be ready to receive DMX signal.

5.1 DMX Controller

If you use a universal DMX controller to control the units, you have to set DMX address from 1 to 512 so that the units can receive DMX signal.







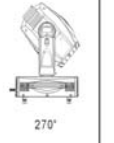

Press the **ENTER** button until the **DMX address** is shown on the monitor. Pressing **ENTER** button and the monitor will blink. Use jog wheel to change the DMX512 address. Once the address has been selected, press the **ENTER** button to setup or automatically return to the main functions without any change after 10 seconds. To go back to the previous functions without any change press the **ESC** button.

Please refer to the following diagram to address your DMX512 channel for the first 4 units.

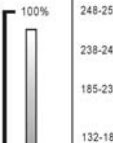
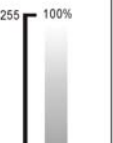
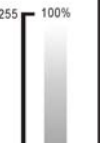
Mode	Fixture 1	Fixture 2	Fixture 3	Fixture 4
16 CH	1	17	33	49
22 CH	1	23	45	67

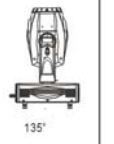
5.2 DMX 512 Configuration

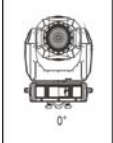
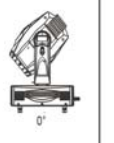
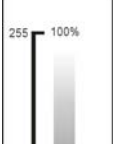
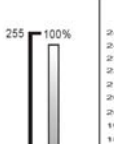
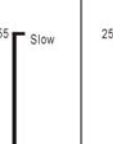
16 Channel Mode

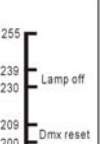
Channel 1	Channel 2	Channel 3	Channel 4	Channel 5	Channel 6	Channel 7	Channel 8
Pan	Tilt	Pan/Tilt speed selection	Dimmer	Shutter	Color	Cyan	Magenta
				248-255 Open 238-247 free shutter 185-237 Fast open-slow close 132-184 Slow open-fast close 131 Fast shutter	255 Fast 192 Slow 191 Slow 128 Fast		
					106-127 Deep blue 085-105 Yellow 064-084 UV 043-063 Green 022-042 Red		
				016 Slow shutter 008-015 Open 000-007 Blackout	000-021 White		
Channel 9	Channel 10	Channel 11	Channel 12	Channel 13	Channel 14	Channel 15	Channel 16
Yellow	3200K filter	Color-mix preset	CMY Color Mix Macro	CMY Speed	Zoom	Effect	Lamp On/Off /Reset
		248-255 Color31 240-247 Color30 232-239 Color29 224-231 Color28 216-223 Color27 208-215 Color26 200-207 Color25 192-199 Color24 184-191 Color23 176-183 Color22 168-175 Color21 160-167 Color20 152-159 Color19 144-151 Color18 136-143 Color17 128-135 Color16 120-127 Color15 112-119 Color14 104-111 Color13 096-103 Color12 088-095 Color11 080-087 Color10 072-079 Color9 064-071 Color8 056-063 Color7 048-055 Color6 040-047 Color5 032-039 Color4 024-031 Color3 016-023 Color2 008-015 Color1 000-007 White	243-255 Marco19 230-242 Marco18 217-229 Marco17 205-216 Marco16 192-204 Marco15 179-191 Marco14 166-178 Marco13 154-165 Marco12 141-153 Marco11 128-140 Marco10 115-127 Marco9 103-114 Marco8 090-102 Marco7 077-089 Marco6 064-076 Marco5 052-063 Marco4 039-051 Marco3 026-038 Marco2 013-025 Marco1 000-012 White			240-255 Frost 033-239 Beam Shape Rotation 016-032 Beam Shppe	

Note: CH-16 functions such as lamp reset, the unit need at least 5 seconds to action..

6. Troubleshooting

Following are a few common problems that may occur during operation. Here are some suggestions for easy troubleshooting:

A. The unit does not work, no light and the fan does not work

1. Check the connect power and main fuse.
2. Measure the mains voltage on the main connector.
3. Check the power on LED.

B. Not responding to DMX controller

1. DMX LED should be on. If not, check DMX connectors, cables to see if link properly.
2. If the DMX LED is on and no response to the channel, check the address settings and DMX polarity.
3. If you have intermittent DMX signal problems, check the pins on connectors or on PCB of the unit or the previous one.
4. Try to use another DMX controller.
5. Check to see if the DMX cables run near or run alongside to high voltage cables that may cause damage or interference to DMX interface circuit.

C. One of the channels is not working well

1. The stepper motor might be damaged or the cable connected to the PCB is broken.
2. The motor's drive IC on the PCB might be out of condition.

D. The lamp is cutting out intermittently

1. The lamp is not working well. Check the main voltage either too high or too low.
2. Internal temperature may be too high. Check and if necessary replace the fan on the head.

E. If The pan belt is broken

1. Turn off the main power.
2. Unscrew all the screws (A) and open the base-housing cover (B).
3. Unplug all the connect wires that upon belt.
4. Loose the screws (D).
5. Change a new belt (C) , put the belt around the axis gear and motor gear.
6. Screwed the screws (D), install the new belt and adjust the belt tension properly.
7. Note: do not fix the belt too tight as it is easy to rupture.
8. Plug all the connect wires back that upon belt.
9. Screw all the screws (A) .

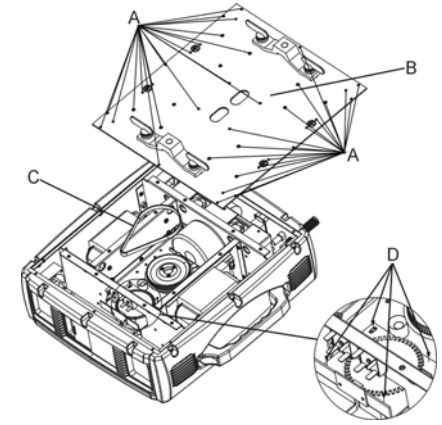

F. If The tilt belt is broken

1. Turn off the main power.
2. Unscrew all the screws (A) and open the right arm cover (B).
3. Unscrew the screws (C) that fix the bridge.
4. Loose the screws (D).
5. Change a new belt (E). Please adjust the tension of the belt properly. Note: do not fix the belt too tight as it is easy to rupture.
6. Reverse the procedures from point 3 to 2 .

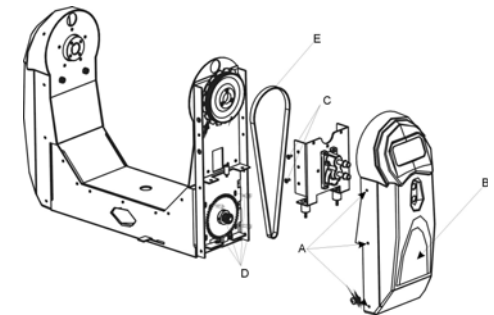

Pay attention to the belt tension when install the belt.

Please refer to the photos below:

Photo 1 : Adjust belt tension through loose this screws (D)

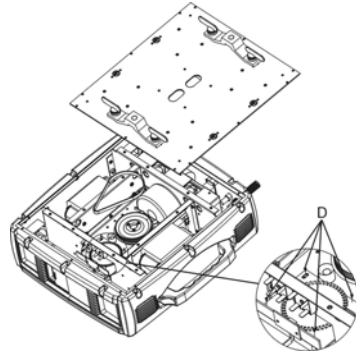
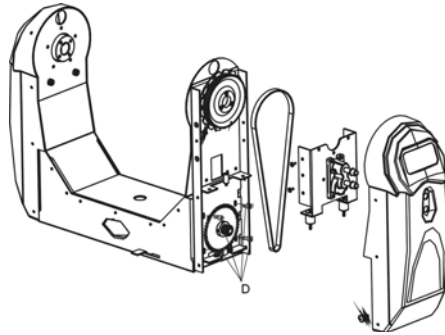

Photo 2 : Adjust belt tension through loose this screws (D)



7. Fixture Cleaning

The cleaning of internal and external optical lenses and/or mirrors must be carried out periodically to optimize light output. Cleaning frequency depends on the environment in which the fixture operates: damp, smoky or particularly dirty surrounding can cause greater accumulation of dirt on the unit's optics.

- Clean with soft cloth using normal glass cleaning fluid.
- Always dry the parts carefully.
- Clean the external optics at least every 20 days. Clean the internal optics at least every 30/60 days.

Professional, Performance, Technology