

iSolution

Your integrated Solution

DMX512

LINKABLE

STAND ALONE

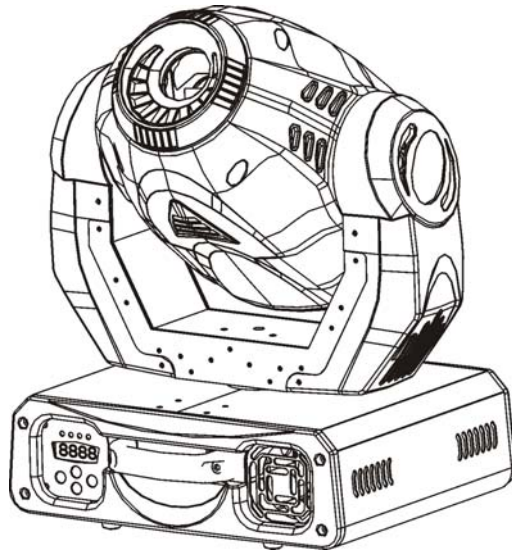

User Guide

Please read these instructions carefully before use

TABLE OF CONTENTS

1. Safety Instruction
2. Technical Specification
3. Lamp
4. How To Set The Unit
 - 4.1 Control Panel
 - 4.2 Main Function
 - 4.3 Home Position Adjust
5. How To Control The Unit
 - 5.1 Master/Slave Built-In Preprogrammed Function
 - 5.2 Easy Controller
 - 5.3 iSolution Operation / DMX Controller
 - 5.4 DMX512 Configuration
 - 5.5 DMX512 Connection
6. Troubleshooting
7. Fixture Cleaning

1. Safety Instruction



WARNING

Please read carefully the instruction, which includes important information about the installation, usage and maintenance.

- Please keep this User Guide for future consultation. If you sell the unit to another user, be sure that they also receive this instruction booklet.
- Unpack and check carefully there is no transportation damage before using the unit.
- Before operating, ensure that the voltage and frequency of power supply match the power requirements of the unit.
- The unit is designed for use with the HMI 575W, HMQ 575/2 or SFc10-4. Do not use any other type of lamp.
- It's important to ground the yellow/green conductor to earth in order to avoid electric shock.
- The unit is for indoor use only. Use only in a dry location.
- The unit must be installed in a location with adequate ventilation, at least 50cm from adjacent surfaces. Be sure that no ventilation slots are blocked.
- Disconnect main power before fuse/lamp replacement or servicing.
- Replace fuse/lamp only with the same type.
- Make sure there are no flammable materials close to the unit while operating, as it is fire hazard.
- Use safety chain when fixes this unit. Don't handle the unit by taking its head only, but always by taking its base.
- Maximum ambient temperature is $T_a : 40^{\circ}\text{C}$. Don't operate it where the temperature is higher than this.
- Unit surface temperature may reach up to 85°C . Don't touch the housing bare-hand during its operation, and allow about 15 minutes to cool down before replacing bulb or serving, as the unit could be very hot.
- In the event of serious operating problem, stop using the unit immediately. Never try to repair the unit by yourself. Repairs carried out by unskilled people can lead to damage or malfunction. Please contact the nearest authorized technical assistance center. Always use the same type spare parts.
- Don't connect the device to any dimmer pack.
- Do not touch any wire during operation as high voltage might be causing electric shock.

Warning

- To prevent or reduce the risk of electrical shock or fire, do not expose the unit to rain or moisture.
- Never touch bulb with bare fingers, as it is very hot after using.
- Hot lamp explosion hazard. Do not open the unit within five minutes after switching off.
- Do not start on the unit without bulb enclosure or housing are damaged.
- The housing, the lenses, or the ultraviolet filter must be replaced if they are visibly damaged.
- Do not look directly at the light while the bulb is on.

Caution

There are no user serviceable parts inside the unit. Do not open the housing or attempt any repairs by yourself. In the unlikely event your unit may require service, please contact your nearest dealer.

Installation

The unit should be mounted via its mounting system (as shown below) on the bottom of the base. Use clamps to fix the unit to truss. Always ensure that the unit is firmly fixed to avoid vibration and slipping while operating. Always ensure that the structure to which you are attaching the unit is secure and is able to support a weight of 50 kgs for each unit. Also always use a safety cable that can hold 10 times of the weight of the unit when installing the fixture.

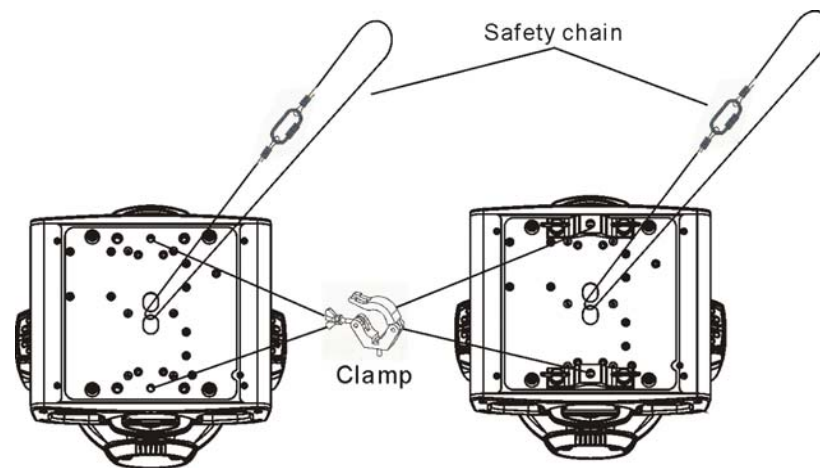

2. Technical Specification

Power supply

- AC 120V~60Hz or AC 230/240/250V~50/60Hz

Lamp

- HMI 575W / HMQ 575/2 SFC10-4

Optical system

- High efficiency optical system
- High quality optical lens and dichroic colors
- Beam angle: 14°

Shutter/Dimmer

- Blackout, 0~100 smooth dimming and strobe speed variable (1~10 flashes/ per second).

Color wheel

- Independent color wheel with 9 trapezoid dichroic colors plus white.
- Color wheel rotates with variable speed, giving rainbow effect.

Gobo wheel

- Independent gobo wheel with 9 different gobos plus open.
- Independent gobo wheel with 7 rotating, replaceable gobos plus open.

Effect Wheel

- Prism/Rotating Prism

Movement

- Pan: 540° in 2.8 second.
- Tilt: 270° in 1.6 second.

DMX Channels

- Standard DMX512 signal addressing and can be controlled by any universal DMX controller.

16 Channels:

Channel 1 = Pan	Channel 9 = Gobo 2
Channel 2 = Tilt	Channel 10 = Gobo2 Rotation
Channel 3 = Pan/Tilt Speed select	Channel 11 = Prism
Channel 4 = Dimmer	Channel 12 = Prism Rotation
Channel 5 = Shutter/Shaking	Channel 13 = Focus
Channel 6 = Color	Channel 14 = Pan 16 bit
Channel 7 = No Function	Channel 15 = Tilt 16 bit
Channel 8 = Gobo 1	Channel 16 = Reset/Lamp on/off

8 Channels:

Channel 1 = Pan
Channel 2 = Tilt
Channel 3 = Shutter
Channel 4 = Gobo
Channel 5 = Color
Channel 6 = Gobo Rotation
Channel 7 = Prism/Prism Rotation/Dimmer
Channel 8 = Focus

Dimension: 427 x 478 x 369 mm (L x W x H)

Weight: 27 kg

2.1. Inserting/Exchanging rotating gobos

Luminous intensity:

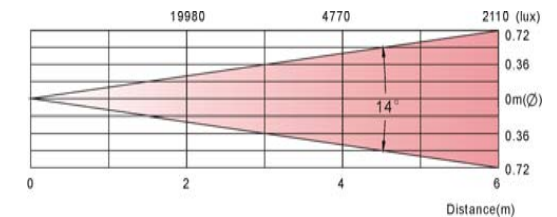

DANGER!

Install the gobos with the device switched off only.

Unplug from mains before changing gobos!

Open the cover by loosening the fastening screw at the sides of the cover.

If you wish to use other forms and patterns as the standard-gobos, or if the gobos are to be exchanged, remove the fixation ring with an appropriate tool. Remove the gobo and insert the new gobo. Press the fixation-ring together and insert it in the front of the gobo.

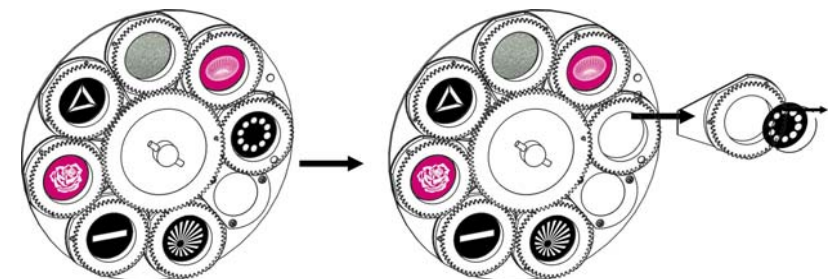

CAUTION!

Never unscrew the screws of the rotating gobo as the ball bearing will otherwise be opened!

3. Lamp



In case of replacement of the lamp or maintenance, do not open the fixture within 15 minutes until the unit cools down after switching off.

Because of its high internal pressure, there might be a risk that the Discharge lamp would explode during operation. The lamp emits intense UV radiation which is harmful to the eyes and skin. The high luminance of the arc can cause severe damage to the retina if looks directly at the lamp.

HMI 575W / HMQ 575/2 SFC10-4

1. Always switch off the main supply and never handle the lamp or luminaire when it is hot.
2. Do not touch the bulb with bare hands. If this happens, clean the lamp with denatured alcohol and wipe it with a lint free cloth before installation.
3. The lamp generates UV radiation. Never operate the lamp without appropriate shielding.
4. When burning, the lamp operates at high pressure and there is a slight risk of arc tube rupture. The risk increases with age, temperature and improper handling of the lamp. Do not use the lamp any longer than its specified life.

Make sure the lamp is located in the center of the reflector for the best spot.

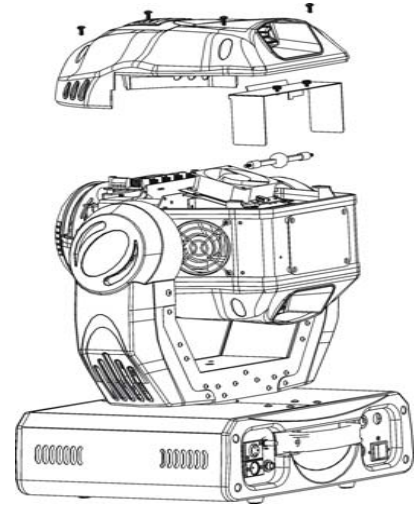

4. How To Set The Unit

4.1. Control Panel

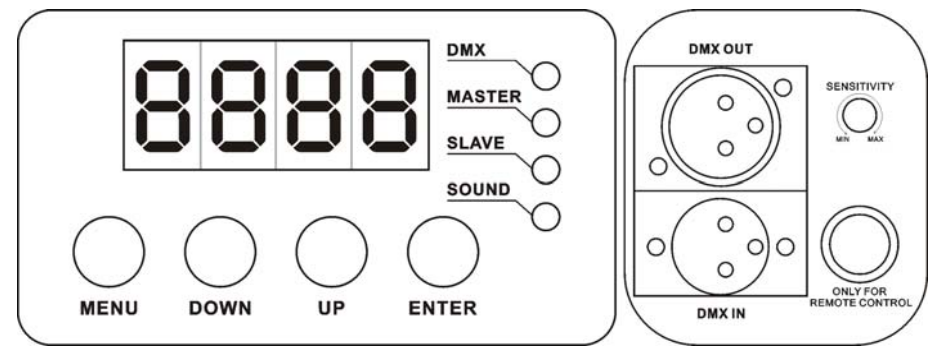

Display

To show the various menus and the selected functions .

LED

DMX	On	DMX input present
MASTER	On	Master mode
SLAVE	On	Slave mode
SOUND	Flashing	Sound activation

Button

MENU	To select the programming functions
DOWN	To go backward in the selected functions
UP	To go forward in the selected functions
ENTER	To confirm the selected functions

Remote controller input

By connecting to the 1/4" microphone jack to control the unit for Stand by, Function, and Mode function.

Sensitivity

To adjust the sound-receiving sensitivity.

DMX input/output

For DMX512 link, use 3-pin XLR plug cable to link the unit together.

4.2. Main Function

To select any of the pre-set functions, press the **MENU** button up to when the required one is shown on the display. Select the function by **ENTER** button and the display will blink. Use **DOWN** and **UP** button to change the mode. Once the required mode has been selected, press the **ENTER** button to setup or it will automatically return to the main functions without any change after idling 8 seconds. To go back to the functions without any change press the **MENU** button. The main functions are shown below:

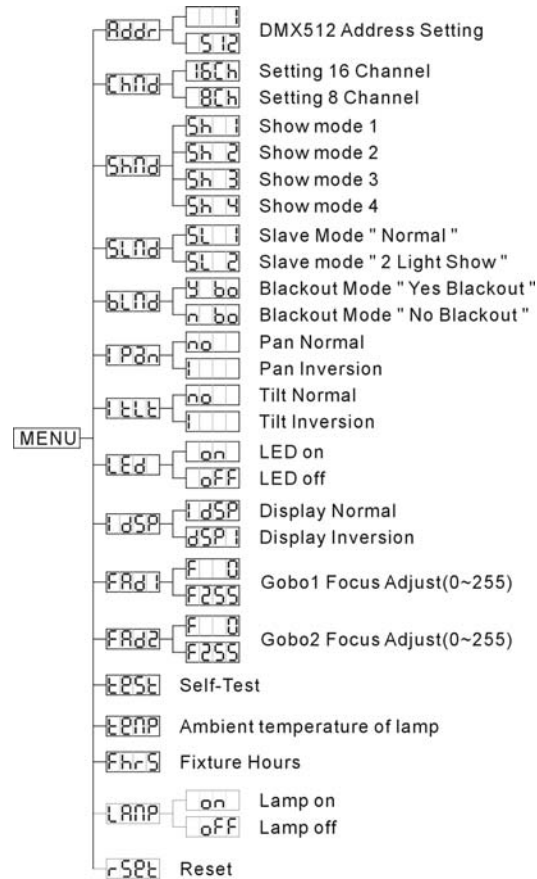

Addr

DMX512 Address Setting

Press the **MENU** button up to when the **Addr** is shown on the display. Pressing **ENTER** button and the display will blink. Use **DOWN** and **UP** button to change the DMX512 address. Once the address has been selected, press the **ENTER** button to setup or automatically return to the main functions without any change after 8 seconds. To go back to the functions without any change press the **MENU** button again.

Chnd

Channel Mode

Press the **MENU** button up to when the **Chnd** is shown on the display. Pressing **ENTER** button and the display will blink. Use **DOWN** and **UP** button to select the **16Ch** (16 Channel) or **8Ch** (8 Channel) mode. Once the mode has been selected, press the **ENTER** button to setup or automatically return to the main functions without any change after 8 seconds. To go back to the functions without any change press the **MENU** button again.

Shnd

Show Mode

Press the **MENU** button up to when the **Shnd** is showing on the display. Pressing **ENTER** button and the display will blink. Use **DOWN** and **UP** button to select the **Sh 1** (show 1) or **Sh 2** (show 2) or **Sh 3** (show 3) or **Sh 4** (show 4) mode. Once the mode has been selected, press the **ENTER** button to setup or automatically return to the main functions without any change after 8 seconds. To go back to the functions without any change press the **MENU** button again.

Sh 1

Show 1 mode - Fixture is placed on the floor. Tilt movement angle 210°.

Sh 2

Show 2 mode - Fixture is fixed under ceiling. Tilt movement angle 90°.

Sh 3

Show 3 mode - Fixture is placed on the speaker, The spot is always projecting to the audience's direction; i.e in front of the stage. Pan movement angle (left to right to left): 160°. Tilt movement angle: 90° (60° above horizon; 30° below horizon).

Sh 4

Show 4 mode - Fixture is fixed under ceiling. The spot is mainly projecting in front of the stage. Pan movement angle (left to right to left):160°. Tilt movement angle: 90° (vertically, front 75°; back 15°).

SLnd

Slave Mode

Press the **MENU** button up to when the **SLnd** is shown on the display. Pressing **ENTER** button and the display will blink. Use **DOWN** and **UP** button to select the **SL 1** (normal) or **SL 2** (2 light show) mode. Once the mode has been selected, press the **ENTER** button to setup or automatically return to the main functions without any change after 8 seconds. To go back to the functions without any change press the **MENU** button again.

BLNd**Blackout Mode**

Press the **MENU** button up to when the **BLNd** is shown on the display. Pressing **ENTER** button and the display will blink. Use **DOWN** and **UP** button to select the **y bo** (yes blackout) or **n bo** (no blackout) mode. Once the mode has been selected, press the **ENTER** button to setup or automatically return to the main functions without any change after 8 seconds. To go back to the functions without any change press the **MENU** button again.

IPan**Pan Inversion**

Press the **MENU** button up to when the **IPan** is shown on the display. Pressing **ENTER** button and the display will blink. Use **DOWN** and **UP** button to select the **no** (normal) or **i** (pan inversion) mode. Once the mode has been selected, press the **ENTER** button to setup or automatically return to the main functions without any change after 8 seconds. To go back to the functions without any change press the **MENU** button again.

TELE**Tilt Inversion**

Press the **MENU** button up to when the **TELE** is shown on the display. Pressing **ENTER** button and the display will blink. Use **DOWN** and **UP** button to select the **no** (normal) or **i** (tilt inversion) mode. Once the mode has been selected, press the **ENTER** button to setup or automatically return to the main functions without any change after 8 seconds. To go back to the functions without any change press the **MENU** button again.

LEd**Led Display**

Press the **MENU** button up to when the **LEd** is showing on the display. Pressing **ENTER** button and the display will blink. Use **DOWN** and **UP** button to select the **on** (Led on) or **off** (Led off) mode. Once the mode has been selected, press the **ENTER** button to setup or automatically return to the main functions without any change after 8 seconds. To go back to the functions without any change press the **MENU** button again.

IDSP**Display Inversion**

It is good for you to install the unit on the floor or under ceiling. Press the **MENU** button up to when the **IDSP** is blinking on the display. Use the **ENTER** button to change to the mode **dSPi** (display inversion), It will automatically store after 8 seconds. Or press the **ENTER** button again return to the mode **IDSP** (display normal). To go back to the functions press the **MENU** button.

IDSP

Display normal mode for the fixture putting on the floor.

dSPi

Display inversion mode for the fixture fixing under ceiling.

FAd1**Gobo1 focus Adjust**

Press the **MENU** button up to when the **FAd1** is blinking on the display. Pressing **ENTER** button, the unit will focus on tilt 135°, and then the unit will first focus on tilt 45°, pan 0°, pan 90°, pan 180°, pan 270° each time your press **ENTER** button. Use **DOWN** and **UP** button to adjust fixable gobo wheel focus. To go back to the functions press the **MENU** button again.

FAd2**Gobo2 focus Adjust**

Press the **MENU** button up to when the **FAd2** is blinking on the display. Pressing **ENTER** button, the unit will focus on tilt 135°, and then the unit will first focus on tilt 45°, pan 0°, pan 90°, pan 180°, pan 270° each time your press **ENTER** button. Use **DOWN** and **UP** button to adjust rotating gobo wheel focus. To go back to the functions press the **MENU** button again.

TEST**Self-Test**

Press the **MENU** button up to when the **TEST** is blinking on the display. Pressing **ENTER** button and the unit will run self-test by built-in program. To go back to the functions press the **MENU** button again.

TEMP**Ambient temperature of lamp**

Press the **MENU** button up to when the **TEMP** is blinking on the display. Pressing **ENTER** button and the ambient temperature of lamp will show on the display. To go back to the functions press the **MENU** button again.

FhrS Fixture Hours

Press the **MENU** button up to when the **FhrS** is blinking on the display. Pressing **ENTER** button and the display will show the number of working hours of the unit. To go back to the functions press the **MENU** button again.

LAMP Lamp ON/OFF

Press the **MENU** button up to when the **LAMP** is blinking on the display. Pressing **ENTER** button and the display will blink. Use **DOWN** and **UP** button to select the **on** (Lamp on) or **off** (Lamp off) mode. Once the mode has been selected, press the **ENTER** button to setup or automatically return to the main functions without any change after 8 seconds. To go back to the functions without any change press the **MENU** button again.

rSEt Reset

Press the **MENU** button up to when the **rSEt** is blinking on the display. Pressing **ENTER** button and all channels of the unit will return to their standard position. To go back to the functions press the **MENU** button again.

DMX RESET:

Set DMX value of channel 16 to 200~209, then all channels of the unit will return to their standard home position after about 5 seconds.

4.3 Home Position Adjust

Press **MENU** button for at least 5 seconds into offset mode to adjust the home position, when you want to adjust gobo and color home position, you should be run **FAdj** mode first, the functions are shown below:

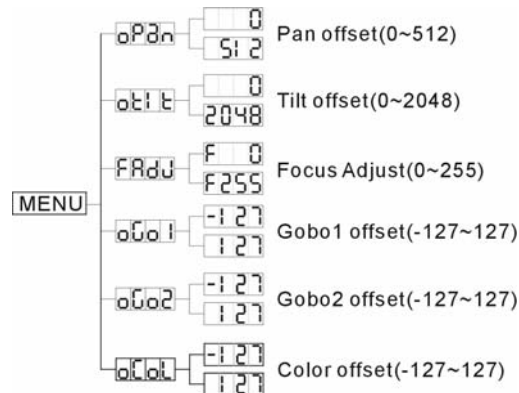

oPAn Pan offset

Press the **MENU** button for at least 5 seconds into offset mode, use **DOWN** and **UP** button up to when the **oPAn** is shown on the display. Pressing **ENTER** button and the display will blink. Use **DOWN** and **UP** button to adjust the pan home position. Once the position has been selected, press the **ENTER** button to setup or automatically return to the offset functions without any change press the **MENU** button again, To go back to the main functions without any change after 8 seconds.

oTilt Tilt offset

Press the **MENU** button for at least 5 seconds into offset mode, use **DOWN** and **UP** button up to when the **oTilt** is shown on the display. Pressing **ENTER** button and the display will blink. Use **DOWN** and **UP** button to adjust the tilt home position. Once the position has been selected, press the **ENTER** button to setup or automatically return to the offset functions without any change press the **MENU** button again, To go back to the main functions without any change after 8 seconds.

FAdj Focus Adjust

Press the **MENU** button for at least 5 seconds into offset mode, use **DOWN** and **UP** button up to when the **FAdj** is shown on the display. Pressing **ENTER** button, the unit will focus on tilt 135°, and then the unit will first focus on tilt 45°, pan 0°, pan 90°, pan 180°, pan 270° each time your press **ENTER** button. Use **DOWN** and **UP** button to adjust focus, this settings only for offset mode to adjust home position. To go back to the main functions without any change after 8 seconds.

oDim Dimmer offset

Press the **MENU** button for at least 5 seconds into offset mode, use **DOWN** and **UP** button up to when the **oDim** is shown on the display. Pressing **ENTER** button and the display will blink. Use **DOWN** and **UP** button to adjust the dimmer home position(0~255). Once the mode has been selected, press the **ENTER** button to setup or automatically return to the offset functions without any change press the **MENU** button again, To go back to the main functions without any change after 8 seconds.



Gobo 1 offset

Press the **MENU** button for at least 5 seconds into offset mode, use **DOWN** and **UP** button up to when the  is shown on the display. Pressing **ENTER** button and the display will blink. Use **DOWN** and **UP** button to adjust the gobo home position. Once the gobo1 has been selected, press the **ENTER** button to setup or automatically return to the offset functions without any change press the **MENU** button again, To go back to the main functions without any change after 8 seconds.



Gobo 2 offset

Press the **MENU** button for at least 5 seconds into offset mode, use **DOWN** and **UP** button up to when the  is shown on the display. Pressing **ENTER** button and the display will blink. Use **DOWN** and **UP** button to adjust the gobo home position. Once the gobo2 has been selected, press the **ENTER** button to setup or automatically return to the offset functions without any change press the **MENU** button again, To go back to the main functions without any change after 8 seconds.



Color offset

Press the **MENU** button for at least 5 seconds into offset mode, use **DOWN** and **UP** button up to when the  is shown on the display. Pressing **ENTER** button and the display will blink. Use **DOWN** and **UP** button to adjust the color home position. Once the color has been selected, press the **ENTER** button to setup or automatically return to the offset functions without any change press the **MENU** button again, To go back to the main functions without any change after 8 seconds.



5. How To Control The Unit







You can operate the unit in three ways:

1. By master/slave built-in preprogram function
2. By easy controller
3. By IL-0824 (only for setting in 8 channel mode, please refer to the user guide of iLead controller) or by universal DMX controller





No need to turn the unit off when you change the DMX address, as new DMX address setting will be effected at once. Every time you turn the unit on, it will show I575 on the display and move all the motors to their 'home' position and you may hear some noises for about 20 seconds. After that the unit will be ready to receive DMX signal or run the built-in program

5.1. Master/Slave Built-In Preprogrammed Function

You can select blackout mode  in  (yes blackout) or  (no blackout) mode while the unit is turned on. By linking the units in master/slave connection, the first unit will control the other units to give an automatic, sound activated, synchronized light show.

This function is good when you want an instant show. You have to select  (show 1) or  (show 2) or  (show 3) or  (show 4) mode by easy controller. Its DMX input jack will have nothing plugged into it, and Its master LED will be constantly on and sound LED will flash to the music. The other units will have to set in slave mode  and select  (normal) or  (2 light show) mode, Their DMX cables plugged into the DMX input jacks (daisy chain) and the slave LED lights will constantly on.

2-light show

In  (slave mode),  means the unit works normally and  means 2-light show. In order to create a great light show, you can set  on the second unit to get contrast movement to each other, even if you have two units only.

5.2. Easy Controller

The easy remote control is used only in master/slave mode. By connecting to the 1/4" microphone jack of the first unit, you will find that the remote control on the first unit will control all the other units for Stand by, Function and Mode.

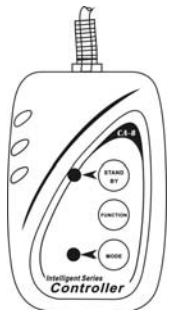

Stand by	Blackout the unit			
Function	Strobe 1. Color sync. strobe 2. Sync. strobe 3. Two-light strobe	X/Y moving show pattern selection (Show 1 ~ Show 4) Please refer to 4.2. Main Functions- Show mode	Gobo/Color selection 1.Hold on for gobo selection 2.Press for color change	X/Y moving setting 1.Pan position 2.Tilt position 3.Dimmer First set Master unit, then set Slave units' position
Mode	Sound 1 (LED off)	Sound 2 (LED slow blinking)	Slow/Sound 3 (LED on)	Position/ Latch (LED fast blinking)

5.3.1 iSolution Operation

- Consistent DMX configuration enable iMove to be linked with iRock and iShow together and controlled at the same time.
- DMX address can be set remotely by iLead controller (please refer to the user manual of iLead controller). No need to calculate the DMX channels of each fixture in the chain.
- Automatic switching between DMX function and built-in stand alone programs.

5.3.2 DMX Controller

If you use a universal DMX controller to control the units, you have to set DMX address from 1 to 512 channel so that the units can receive DMX signal.

Press the **MENU** button up to when the **Addr** is shown on the display. Pressing **ENTER** button and the display will blink. Use **DOWN** and **UP** button to change the DMX512 address. Once the address has been selected, press and keep **ENTER** button pressed up to when the display stops blinking or storing automatically 8 seconds later. To go back to the functions without any change press the **MENU** button again.

Please refer to the following diagram to address your DMX512 channel for the first 4 units.

16 Channels:

8 Channels:

You have to set the fixture DMX address in 8 channels mode when you use IL-0824 controller. DMX address can be set remotely by IL-0824 controller. No need to calculate the DMX channels of each fixture in the chain.

Please refer to the following diagram to address your DMX512 channel for the first 4 units.

8 Channels:

5.4. DMX512 Configuration

16 Channels DMX-512 Configuration							
Channel 1	Channel 2	Channel 3	Channel 4	Channel 5	Channel 6	Channel 7	Channel 8
Pan	Tilt	Pan/Tilt speed select	Dimmer	Shutter/Shaking	Color	No function	Gobo1
Channel 9	Channel 10	Channel 11	Channel 12	Channel 13	Channel 14	Channel 15	Channel 16
Gobo2	Gobo2 Rotation	Prism	Prism Rotation	Focus	Pan 16 bit	Tilt 16 bit	Reset Lamp On/Off

i.) During the 16 channels condition, for DMX reset, put DMX value of CH-8 & CH-16 equal to 255, the unit will reset after about five seconds.

For lamp on, put CH-8 value to 247 and Ch-16 to 255.













For lamp off, put CH-8 value to 239 and Ch-16 to 255.

ii.) For color sound activated, put Ch-6 & Ch-7 values equal to 255.

For gobo sound activated, put CH-8 & CH-9 values equal to 255.

5.5. DMX512 Connection

The DMX512 is widely used in intelligent lighting control, with a maximum of 512 channels.

8 Channels DMX-512 Configuration							
Channel 1	Channel 2	Channel 3	Channel 4	Channel 5	Channel 6	Channel 7	Channel 8
Pan	Tilt	Shutter/Shaking	Gobo	Color	Gobo rotation	Prism/Prism rotation /Dimmer	Focus
 540°	 270°	240-255 Open 240-247  239 Fast shaking (gobo2) 186 Slow shaking (gobo2) 185 Fast shaking (gobo1) 132 Slow shaking (gobo1) 131 Fast shutter  16 Slow shutter 008-015 Open 000-007 Blackout	248-255  247 Fast Gobo2 218 Slow 217 Slow iGobo2 188 Fast 187 Fast Gobo1 158 Slow 157 Slow Gobo1 128 Fast 124-127 G15+G9 120-123 G15+G7 116-119 G15+G5 112-115 G15+G3 108-111 G15+G1 104-107 G13+G9 100-103 G13+G7 096-099 G13+G5 092-095 G13+G3 088-091 G13+G1 084-087 G10+G9 080-083 G10+G7 076-079 G10+G5 072-075 G10+G3 068-071 G10+G1 064-067 G16 060-063 G15 056-059 G14 052-055 G13 048-051 G12 044-047 G11 040-043 G10 036-039 G9 032-035 G8 028-031 G7 024-027 G6 020-023 G5 016-019 G4 012-015 G3 008-011 G2 004-007 G1 000-003 Open	248-255  247 Fast 188 Slow 187 Slow 128 Fast 115-127 Pink 102-114 Light green 089-101 UV purple 077-088 Blue 064-076 Red 051-063 Yellow 039-050 Light blue 026-038 Magenta 013-025 Green 000-012 White	246-255 Stopped 245 Fast 135 Slow 121-134 Stopped 120 Slow 010 Fast 000-009 Stopped	255 100% Dimmer 128 0% 127 Fast 104 Slow 103 Slow Prism effect 2 080 Fast 079 Fast Prism effect 1 056 Slow 055 Slow Prism effect 1 032 Fast 016-031 000-015 Open	 255 0
 270°	 135°						 
 0°	 0°						

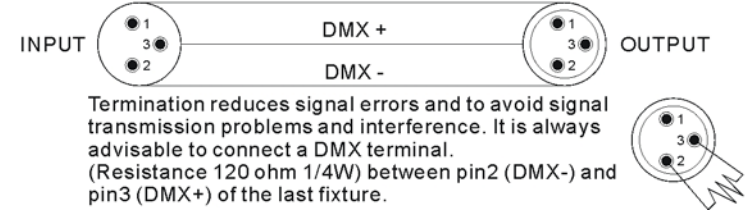
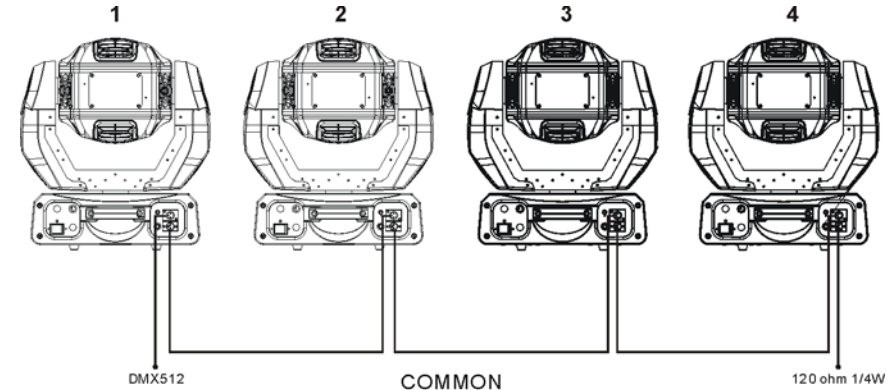

- If you use a controller with 5 pins DMX connector, you need to use a 5 to 3 pin adapter.
- At last unit, the DMX cable has to be terminated with a terminator. Solder a 120-ohm 1/4W resistor between pin 2(DMX-) and pin 3(DMX+) into a 3-pin XLR-plug and plug it in the DMX-output of the last unit.
- Connect the unit together in a “daisy chain” by XLR plug from the output of the unit to the input of the next unit. The cable cannot be branched or split to a “Y” cable. DMX512 is a very high-speed signal. Inadequate or damaged cables, soldered joints or corroded connectors can easily distort the signal and shut down the system.
- The DMX output and input connectors are pass-through to maintain the DMX circuit, when power is disconnected to the unit.
- Each lighting unit needs to have an address set to receive the data sent by the controller. The address number is between 0-511 (usually 0 & 1 are equal to 1).
- The end of the DMX512 system should be terminated to reduce signal errors.
- 3 pin XLR connectors are more popular than 5 pins XLR.
 3 pin XLR: Pin 1: GND, Pin 2: Negative signal (-), Pin 3: Positive signal (+)
 5 pin XLR: Pin 1: GND, Pin 2: Negative signal (-), Pin 3: Positive signal (+)

6. Troubleshooting

Following are a few common problems that may occur during operation. Here are some suggestions for easy troubleshooting:

A. The unit does not work, no light and the fan does not work

1. Check the connect power and main fuse.
2. Measure the mains voltage on the main connector.
3. Check the power on LED.

B. Not responding to DMX controller

1. DMX LED should be on. If not, check DMX connectors, cables to see if link properly.
2. If the DMX LED is on and no response to the channel, check the address settings and DMX polarity.
3. If you have intermittent DMX signal problems, check the pins on connectors or on PCB of the unit or the previous one.
4. Try to use another DMX controller.
5. Check in the DMX cables run near or run alongside to high voltage cables that may cause damage or interference to DMX interface circuit.

C. Some units don't respond to the easy controller

1. You may have a break in the DMX cabling. Check the LED for the response of the master/slave mode signal.
2. Wrong DMX address in the unit. Set the proper address.

D. No response to the sound

1. Make sure the unit is not receiving DMX signal.
2. Check microphone to see if it is good by tapping the microphone.

E. One of the channels is not working well

1. The stepper motor might be damaged or the cable connected to the PCB is broken.
2. The motor's drive IC on the PCB might be out of condition.

F. The lamp is cutting out intermittently

1. The lamp is not working well. Check the main voltage either too high or too low.
2. Internal temperature may be too high. Check and if necessary replace the fan on the head.

G. If The pan belt is broken

1. Turn off the main power.
2. Unscrew all the screws (A) and open the base-housing cover (B).
3. Unscrew all the screws (C) and open the arm cover (D).
4. Unplug all the connect wires that from the arm to the bottom.
5. Unscrew the screws (E) and remove the fixture head.
6. Loose the screws (F), then loose the screws (G).
7. Change a new belt (H) , put the belt around the axis gear and motor gear.
8. Screwed the screws (G), install the new belt and adjust the belt tension properly. Note: it is too tight to rupture.
9. Plug all the connect wires back that form the bottom to the arm.
10. Reverse the procedures from point 5 to point 2.

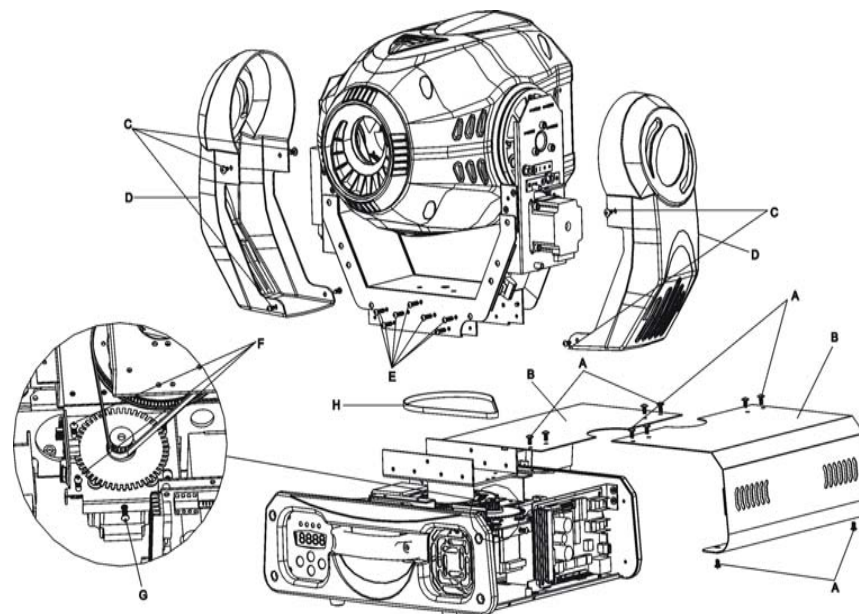

F. If The tilt belt is broken

1. Turn off the main power.
2. Unscrew all the screws (A) and open the right arm cover (B).
3. Unscrew the screws (C), the screws (D) and screws (E) that fix the bridge.
4. Change a new belt (F). Please adjust the tension of the belt properly. Note: it is too tight to rupture.
5. Reverse the procedures from point 3 to 2 .

Pay attention to the belt tension when install the belt.

Please refer to the photos below:

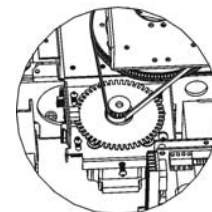
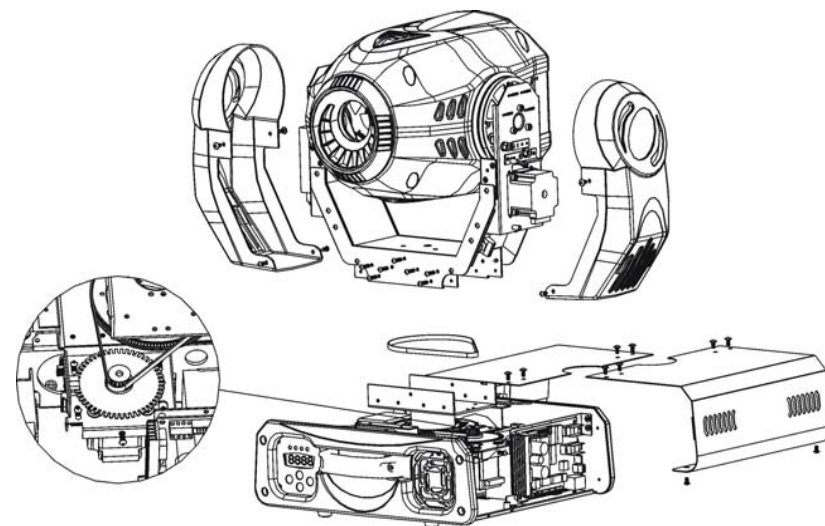
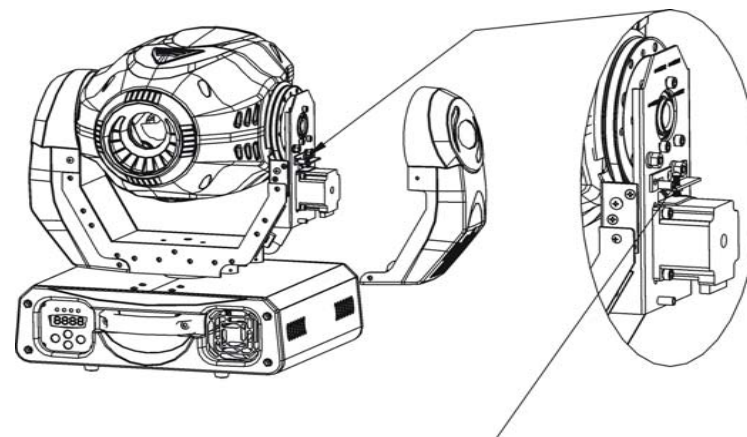

Photo 1



Adjust belt tension through loose the screw

Photo 2

7. Fixture Cleaning

The cleaning of internal and external optical lenses and/or mirrors must be carried out periodically to optimize light output. Cleaning frequency depends on the environment in which the fixture operates: damp, smoky or particularly dirty surrounding can cause greater accumulation of dirt on the unit's optics.

- Clean with soft cloth using normal glass cleaning fluid.
- Always dry the parts carefully.
- Clean the external optics at least every 20 days. Clean the internal optics at least every 30/60 days.

EC Declaration of Conformity

We declare that our products (lighting equipments) comply with the following specification and bears CE mark in accordance with the provision of the Electromagnetic Compatibility (EMC) Directive 89/336/EEC.

EN55014-2: 1997 A1:2001, EN61000-4-2: 1995; EN61000-4-3:2002;
EN61000-4-4: 1995; EN61000-4-5: 1995, EN61000-4-6:1996,
EN61000-4-11: 1994.

&

Harmonized Standard

EN60598-1: 2000+ALL:2000+A12:2002
Safety of household and similar electrical appliances
Part 1 : General requirements

Innovation , Quality , Performance